

PCWJ Series Vortex Flow Meter

Introduction

The series of Vortex Flow Meter is based on Von Karman's Vortex Principle, which adopts piezoelectric crystal as testing components. It is a new kind of stress detecting vortex flow meter. It has the advantages of wide range rate, high accuracy, low pressure loss, good medium generality, pulse signal output proportional to flow, convenient to connect with computer etc. As the detector probe of sensor and the vortex generating body are installed separately, and the high temperature resistant piezoelectric crystal doesn't contact with medium, so the instrument is of simple structure, good generality, and high stability.

PCWJ series Vortex Flow Meter can be used to detect and measure the flow of all kinds of gas, fluid and steam.

PCWJ flow meter sensor can be used to match with our company's MT6000 series flow totalizer. It also can match with computers and sensors of temperature, pressure, or density to compose high-accuracy mass flow or heat flow detecting and measuring system.

Working principle

Vortex flow meters measure flow rate by detecting the frequency at which alternating vortices are shed from a bluff body inserted into the flow stream. This principle of measurement is known as Von Karman's vortex street principle: alternating vortices form behind an object in a stream (Show in the picture). When $d/D=0.28$, released vortices are stable (D is diameter of the pipe). The Vortex shedding frequency is related to width of the bluff body and flow velocity, formula as bellow:

$$f = St \cdot v / d$$

f = vortex shedding frequency [Hz]

St = Coefficient (Strouhal number)

V = flow velocity [m/s]

d = width of the bluff body [m]

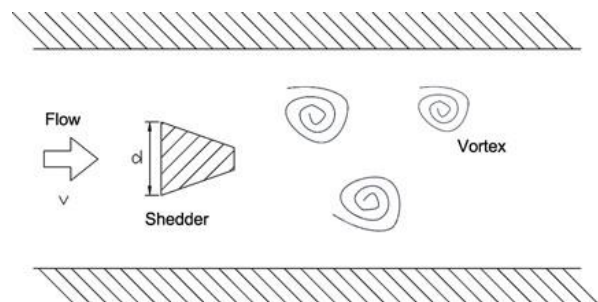

Strouhal Number is a very important coefficient in vortex flow meter, within the range from Reynolds number, Strouhal Number is close to a constant. As showing in the followed chart, $St=0.17$, vortex shedding frequency is proportional to the flow velocity, from f can be calculated V , the flow range can be calculated by V .

PCWJ series Vortex flow meter is a stress type flow meter, the released frequency from sensor is detected by the internal piezoelectric element through sensor (probe).

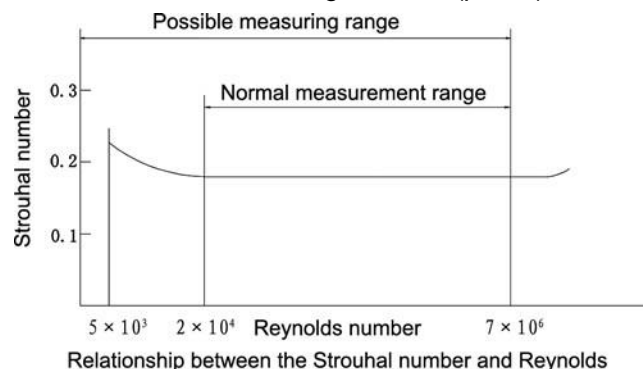

Technical parameters

Measuring medium	Steam, gas, liquid (Avoid of multiple-direction fluid)
Accuracy	Liquid: 1.0% Gas: 1.5%
Repeatability	Liquid: 0.33% Gas: 0.5%
Range	Liquid: 0.7m/s~7m/s Gas: 7m/s~40m/s
Working pressure	Standard 1.6MPa, 2.5~4.0MPa (on request)
Fluid temperature	-40°C~250°C (Common type); 100°C~ 350°C (High-temperature type)
Body material	304 stainless steel (SS316 is optional)
Output signal	Pulse (three wires, low level≤1V; High level ≥ 4V); 4~20mA; RS485
Power supply	24VDC (12VDC), Lithium battery
Ambient temperature	-35°C~ 60°C (without LCD); -5°C~60°C(with LCD)
Relative humidity	5~95%
Protection level	IP65
Electrical connection	M20*1.5
Explosion-proof	Optional

- The structure of Vortex flow meter is simple and strong, no movable parts, and it is very stable.
- Simple installation and easy maintenance
- Wide measuring range, the ratio is up to 10:1
- Low pressure loss and operating costs.
- When measuring the volume of fluid, compensate as required, replace parts without re-calibrate the flow meter.

Structure

Consist of converter (with amplifier board), bracket, bluff body components (Triangular prism, probe) and body, the picture as below:

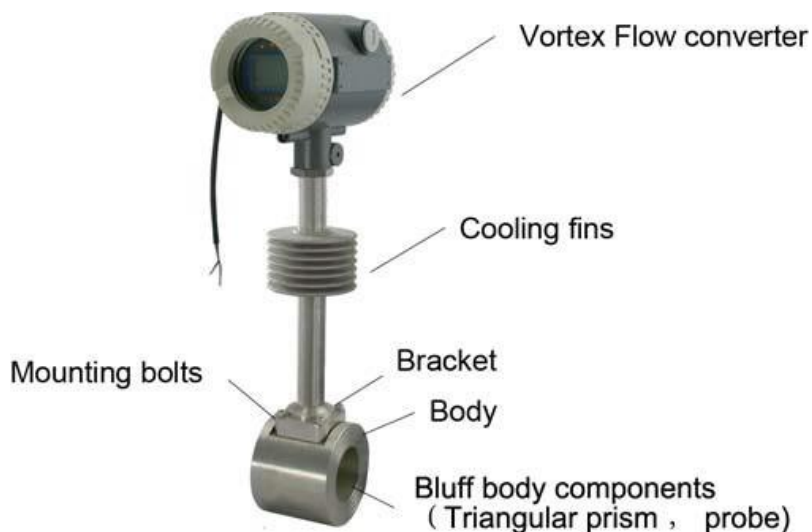

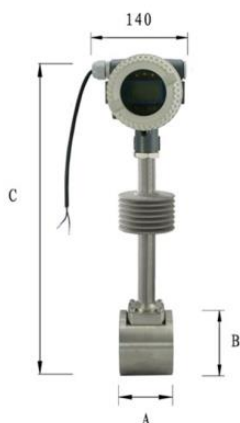

DN	A	B	C
25	65	65	368
32	66	65	374
40	80	76	382
50	80	89	388
65	93	102	402
80	100	114	408
100	126	136	435
125	146	160	463
150	166	182	489
200	196	248	543
250	210	282	596
300	240	334	648

Installation

Vortex flow meters have different structures and installations, maintenance man should know the specific structure, the convert signal, and all the links during the signal transmission. In order to make sure the instrument can work properly, the installation should follow the operated manual.

1. Reasonable installation site and environment.

Avoid strong electrical equipment, high-frequency equipment, strong power switching devices; high temperature heat source and the effects of radiation, and strong vibration field and highly corrosive environments, think about the place easy to install and maintenance.

2. Enough straight pipe for up and down stream.

If there is a tapered tube with more than 15° located in the upstream, then the upstream straight $\geq 15D$, the downstream straight $\geq 5D$.

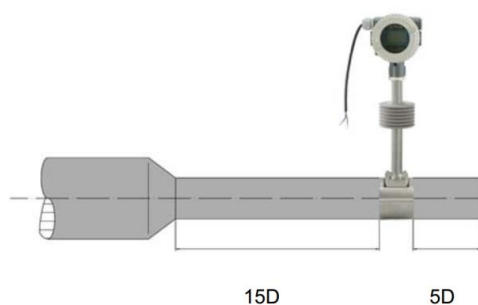

If there is a diverging tube with more than 15° located in the upstream, then the upstream straight $\geq 18D$, the downstream straight $\geq 5D$.

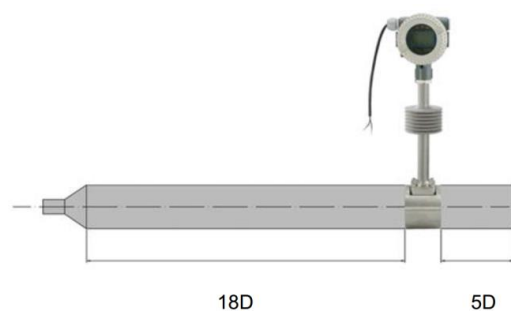

If there is a elbow or T-joint with 90°, then the upstream straight $\geq 20D$, the downstream straight $\geq 5D$.

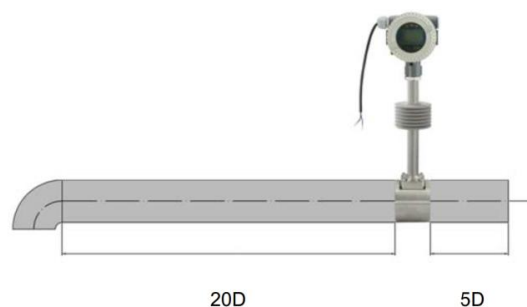

If the upstream of sensor mounting point with two 90 degree elbows is in the same plane, then the length of upstream straight pipe should not be $\leq 25D$, the downstream should not be $\leq 5D$.

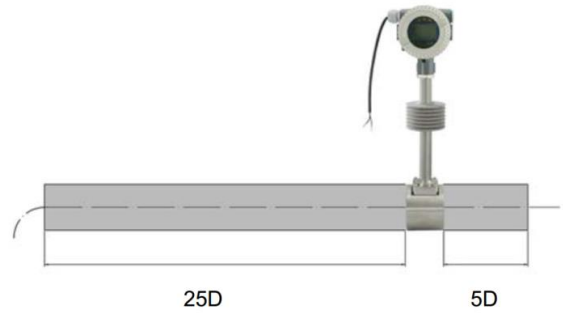

If the upstream of sensor mounting point with two 90 degree elbows is in the different plane, then the length of upstream straight pipe should not be $\leq 40D$, the downstream should not be $\leq 5D$.

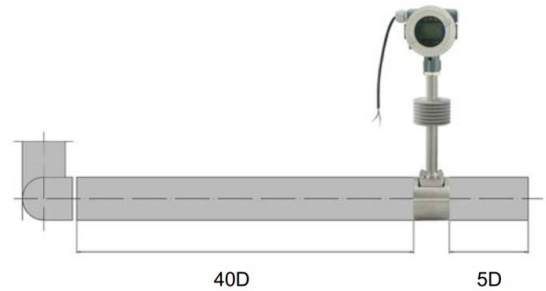

The valve should be installed at least $5D$ away from the downstream of sensor, if the valve must be installed on the upstream of sensor, the length of upstream straight pipe should not be $\leq 50D$, the downstream should not be $\leq 5D$.

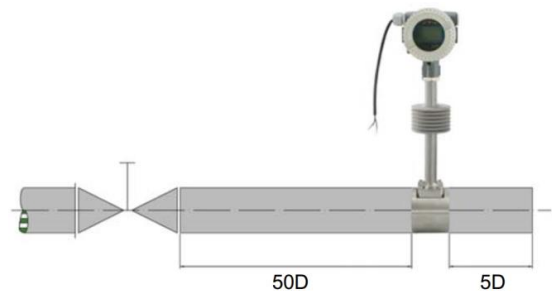

3. The upstream/downstream pipe of mounting point should be concentric with the sensor and the coaxial deviation should not be less than $0.5DN$.

The inner diameter of the upstream and downstream pipe should be the same as the diameter of the sensor; it should meet the following formula:

$$0.98DN \leq D \leq 1.05DN$$

In which: DN ---the diameter of the sensor;

D ---the inner diameter of the pipe

The seal between the sensor and flange can not protrude into the pipe, the internal diameter of it should be greater than the diameter of the sensor.

4. Pipe vibration reduction measures taken.

It is best not to install the sensor on the pipe with high vibration, especially for lateral vibration, and vibration reduction measures must be taken if it is forced to install. And the fastening device and anti-vibration mat should be separately equipped $2D$ away from the upstream-downstream of the sensor.



5. The most commonly-used installation of flow sensor on the horizontal pipe.

When measuring the gas, if the measured gas contains a small amount of liquid, the sensor should be installed on the higher place of the pipe.

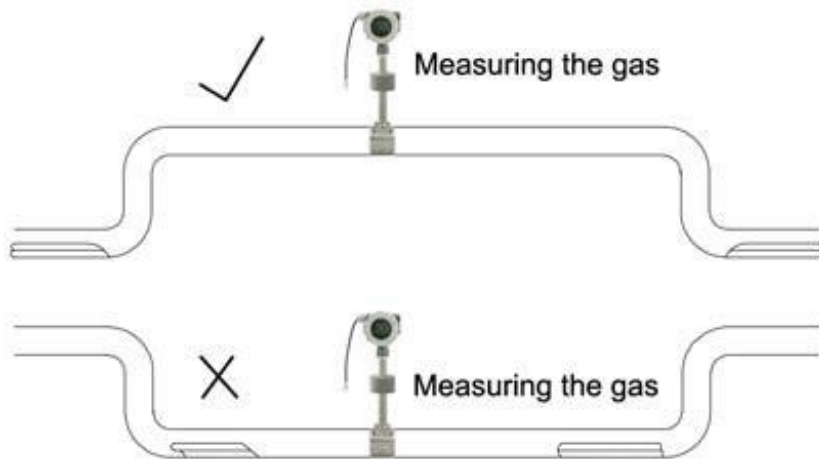

When measuring the liquid, if the measured liquid contains a small amount of gas, the sensor should be installed on the lower place of the pipe.

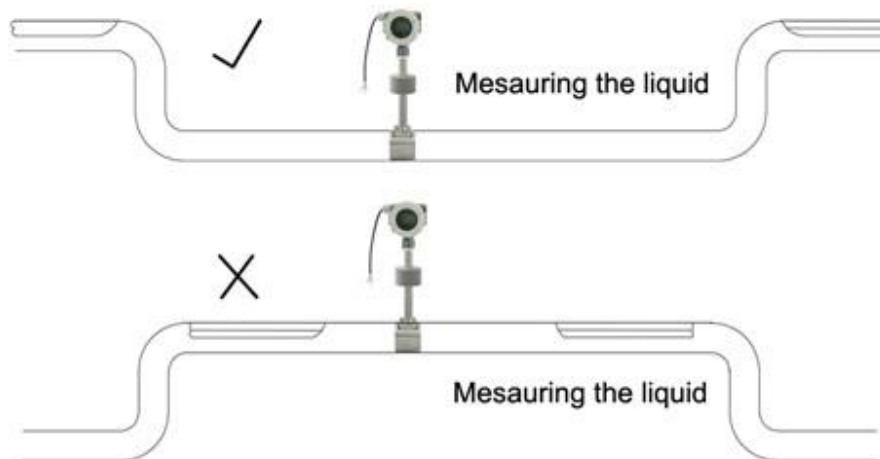

6. The installation of sensor on the vertical pipe

When measuring the gas flow, the sensor could be installed on the vertical pipe with unlimited flow; if the measuring gas contains small amount of liquid, the flow direction of gas should be from top to bottom.

When measuring the liquid flow, the direction should be from bottom to top, so this will not add the extra weight on the probe.

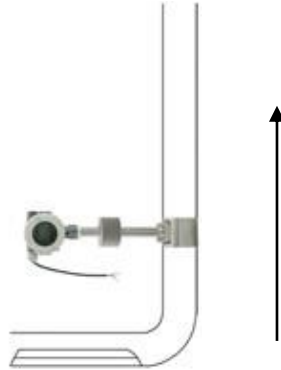

7. Side-installed of the sensor on the horizontal pipe

Whatever fluid you measure, the sensor can be side-installed, this installation would be better especially for measuring the hot steam, saturated steam and cryogenic liquid, and on this condition the temperature of the liquid has little influence on the amplifier.



8. Reversal installation of the sensor on the horizontal pipe.

Generally, we do not recommend the installation, and it is not suitable for measuring universal gas, superheated steam but can be used for measuring saturated steam, high temperature liquid or the pipe need to be cleaned frequently.



9. The installation of the sensor on the insulation layer pipe.

When measuring high temperature steam, the insulation layer can not exceed a maximum of one-third of the height of the stand.

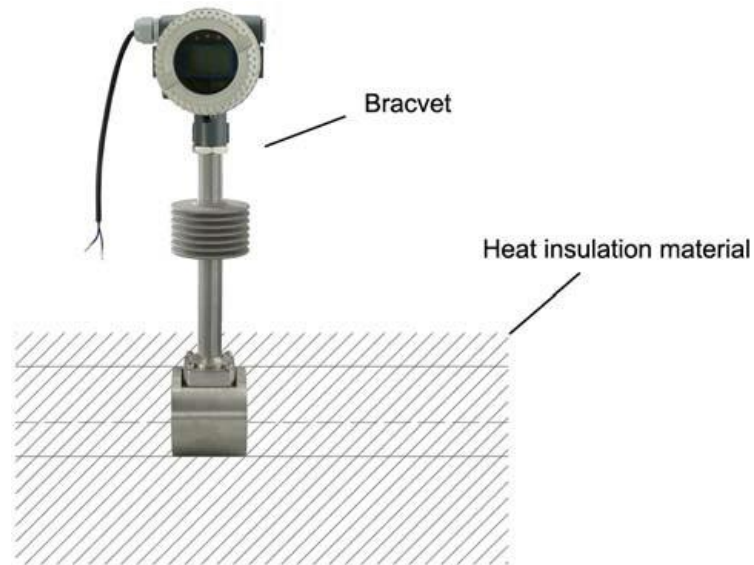

10. The selection of pressure detecting point and temperature detecting point.

According to the measurement requirement, pressure and temperature formula measurement around the sensor is needed, and the pressure detecting point should be 3-5D from the downstream of the sensor, as the temperature detecting point should be 6-8D.

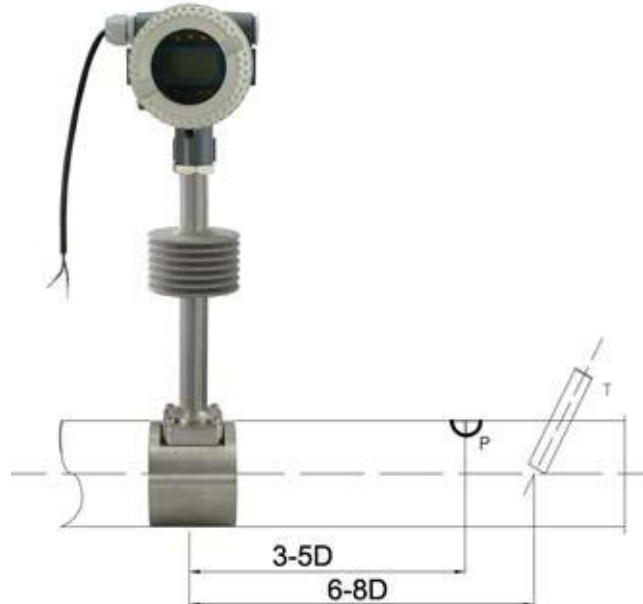

The wiring of the vortex flow meter

General principle: Shielded cable would be used in the places susceptible to electrical noise interference; the shield should be securely connected to the amplifier's grounding screw or adopt work-ground in the control room. Special shield should be used when in high or low temperature environment or the site air containing oil, solvents or other corrosive gases.

1. The wiring of frequency signal output

A three-wire transmission should be used between the frequency output flow meter and other equipments; as the supply power is 24 VDC \pm 10%(12 DC), the minimum load resistance of the output circuit is 10 k Ω , and the maximum capacitance is 0.2UF.

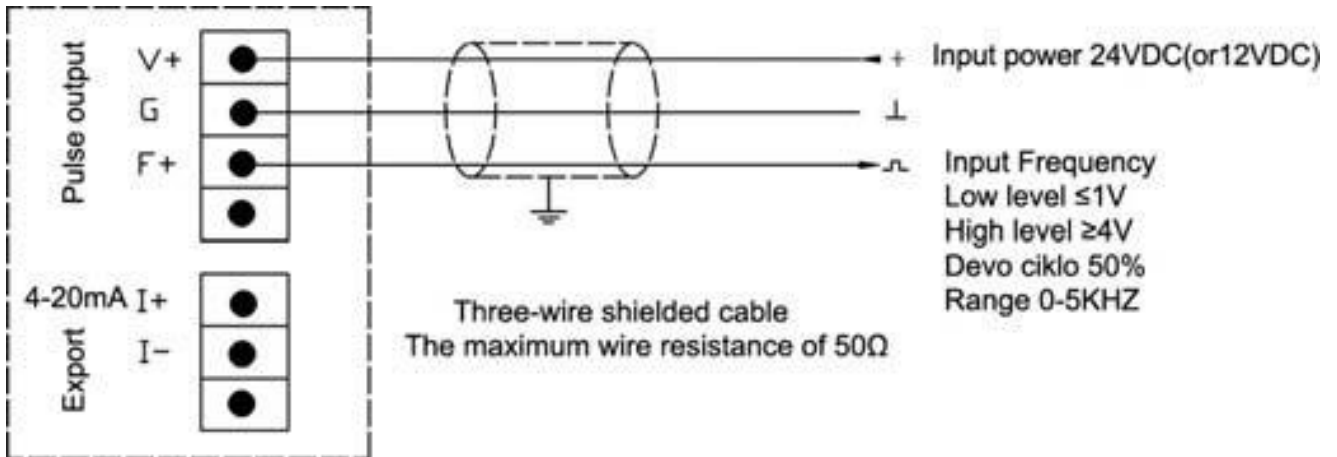

2. The wiring of 4-20mA signal output

A two-wire transmission should be used between the 4-20mA signal output vortex flow meter and other equipments; as the supply power is 24 VDC \pm 10%, the minimum load resistance of the output circuit is 600 Ω (including the cable resistance).

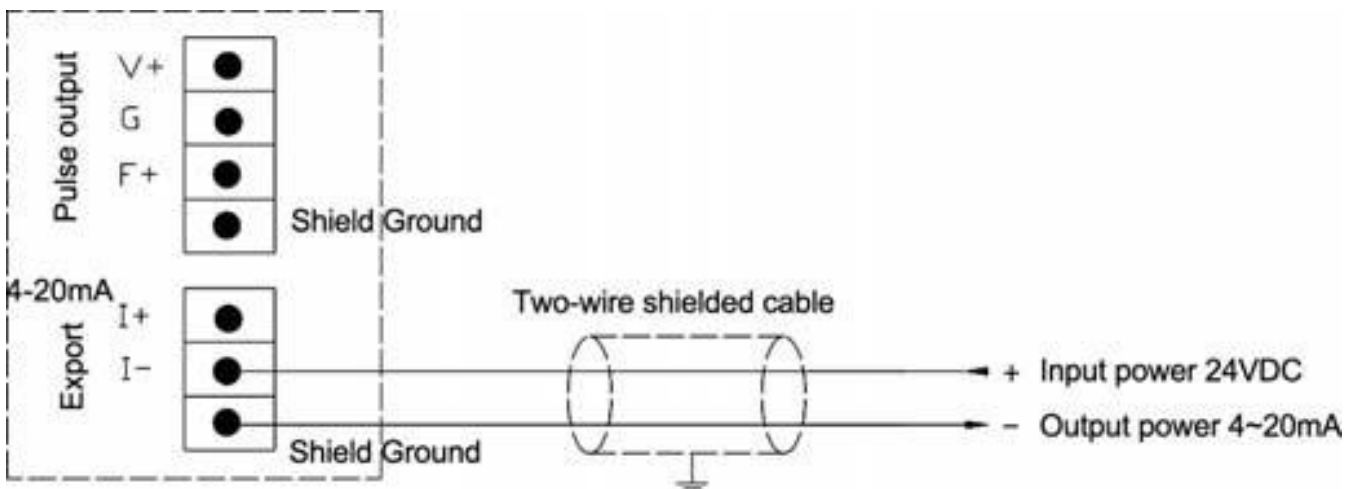

Customer order information table

Type	PCWJ		
Installation method	D	Clamp type sensor	
	F	Flange type sensor	
	--L	Measure flow of liquid	
	--G	Measure flow of gas	
	--S	Measure flow of steam	
Nominal diameter	25	25mm	
	32	32mm	
	---	---	
	80	80mm	
	---	---	
	300	300mm	
Power supply	A	Duplicate supply (24VDC/12VDC, 3.6 Lithium battery)	
	D	3.6V Lithium battery	
	E	24VDC/12VDC	
Display	D	With digital display	
	N	Without display	
Output signal	N	No output	
	P	Pulse	
	A	4 ~ 20	
	R	RS485	
Sensor material	A	304 Stainless steel	
	B	316L Stainless steel	
	O	Other material	
Liquid temperature	--E	-40°C ~ 250°C	
	--H	100°C ~ 350°C	
Pressure	16	1.6MPa	
	25	2.5MPa	
	40	4.0MPa	
	Y	Others	
Protection grade	--0	IP65	
Explosion-proof grade	0	Non explosion proof	
	EX	Explosion proof	

Note for type selection and usage

1. Vortex flow meter is a kind of velocity type flow meter, the steadiness of whirlpool separation is affected by velocity distribution, so when fixing the vortex flow meter, the user must install enough straight pipes on the up and down end to adjust the flow status;
2. Vortex flow meter is not applicable for measuring very low Reynolds number flows, normally require Reynolds number $\geq 2 \times 10^5$
3. When the whirlpool occurs, the partial pressure inside the pipe will drop obviously, when measuring the liquid, when partial pressure drop to the pressure of corresponding saturated steam of liquid temperature, cavitation phenomenon will happen, and damage the pressure detecting components or make the instrument stop working, when install and use the meter need to pay attention to this point.
4. Users need to master the following technical parameters before selecting the type of vortex flow meter:
 - Liquid description, ingredient, corrosion, abrasion etc
 - Minimum, normal, maximum working pressure
 - Minimum, normal, maximum working temperature
 - Viscosity under working condition
 - For gas still need to know the relative humidity
 - The flow characteristic inside the pipe: steady flow, Variable flow, pulsating flow, the gas-liquid two-phase flow, the liquid-liquid two-phase flow etc
 - Flow status: clean or dirty
 - Field environment and installation conditions etc
 - Explosion-proof requirement of the instrument

Wotian reserves the right to make any change in this publication without notice. The information provided is believed to be accurate and reliable as of this product sheet.

Contact us

Nanjing Wotian Technology Co., Ltd.

Add: 5 Wenying Road, Binjiang Development Zone, Nanjing, 211161, China

E-mail : dr@wtsensor.com