

PCPR02 Paperless Recorder

Features

- Up to 18 analog signal input channels, 4 relay alarm outputs.
- 150mA power distribution output and 1 RS-485 communication interface.
- 1 USB data dump interface.
- 64Mb, 96Mb, 128Mb memory available.
- Support boot interface custom writing.
- Support display screenshot function.
- The shell is made of flame retardant material.

Applications

- Metallurgy
- Oil
- Chemical
- Building materials
- Papermaking
- Food
- Pharmaceutical
- Heat treatment
- Water treatment
- PID adjustment

Notes:

- 1 Do not touch the diaphragm with hard objects, which may cause damage to the diaphragm.
- 2 Please read the Instruction Manual of the product carefully before installation and check the relevant information of the product.
- 3 Strictly follow the wiring method for wiring, otherwise it may cause product damage or other potential faults.
- 4 Misuse of the product may cause danger or personal injury.

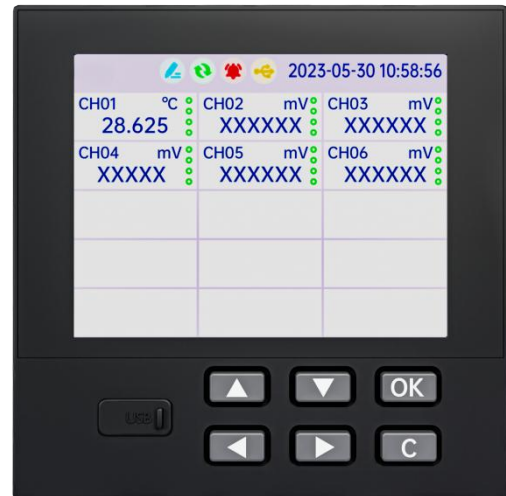

Product overview

This product is an industrial paperless recorder with a 3.5-inch TFT true-color full-view LCD display. Various types of current, voltage, thermocouple and thermal resistance, and other industry standard signals can be connected to realize the display, recording, overrun monitoring, report, data communication, signal transmission and Flow accumulation, flow temperature and pressure compensation, and other functions.

Notes:

- 1 Do not misuse documentation.
- 2 The information presented in this product sheet is for reference only. Do not use this document as a product installation guide.
- 3 Complete installation, operation, and maintenance information is provided in the instructions of the product.
- 4 Misuse of the product may cause danger or personal injury.

Performance parameters	
Display	3.5-inch TFT true-color LCD display, resolution 320*240, high-definition LED backlight
Dimensions	Dimensions: 96mm×96mm×100mm Hole size: 92mm×92mm
Mounting panel thickness	1.5mm~6.0mm
Weight	0.37kg
Power supply	(85~264)VAC, (47~63)Hz (optional 24VDC power supply)
Internal storage	64M Bytes Flash (optional 96M, 128M)
External dump	Support U disk (standard USB2.0 communication interface)
Maximum power consumption	10W
Relative humidity	(10~85)% (no condensation)
Operating temperature	(0~50)°C
Transport and storage conditions	Temperature(-20~60)°C Relative humidity (5~95)% (no condensation)
Power distribution specification	150mA, 24 VDC
Power down protection	All data are stored in Flash memory to ensure that all historical data and configuration parameters will not be lost due to power failure. The real-time clock is powered by an internal battery after power failure.
Alarm output	Up to 4 channels, relays are normally open contacts, contact capacity 2A /250VAC (resistive load)
Communication interface	1 way RS-485 communication interface
Protocol	Using Modbus communication protocol
The sampling period	1s

Input Signal

DC Voltage/Current Input				
Signal type		Maximum allowable error (%FS)		
(1~5)V		±0.1		
(0~10)V				
(0~5)V				
(4~20)mA				
(0~20)mA				
(0~10)mA				
(0~100)mV		±0.2		
(-20~20)mV				
(0~20)mV				
Thermocouple Input (Without Cold Junction Error)				
Signal type	Measuring range (°C)	Maximum allowable error (°C)		
B	600 ~ 1800	±2.4		
E	-200 ~ 1000	±2.4		
J	-200 ~ 1200	±2.4		
K	-200 ~ -100	±3.3		
	-100 ~ 1300	±2.0		
S	-50 ~ 100	±3.7		
	100 ~ 300	±2.0		
	300 ~ 1600	±1.5		
T	-200 ~ -100	±1.9		
	-100 ~ 400	±1.6		
R	-50 ~ 100	±3.7		
	100 ~ 300	±2.0		
	300 ~ 1600	±1.5		
N	-200 ~ 1300	±3.0		
WRe5-26	0~ 2310	±4.0		
WRe3-25	0~ 2315	±4.0		
RTD Input				
Signal type	Measuring range (°C)	Maximum allowable error (°C)		
Cu50	-50 ~ 150	±1.0		
Pt100	-200 ~ 650	±1.0		
Pt1000	-200 ~ 200	±1.0		
Note: special type thermal resistance can be customized.				
Output Signal				
Alarm Output				
Signal type	Measuring range	Contact type	Contact rating	Response cycle
Alarm Output	0/1	Normally open contact	2A /250VAC	1 second
Current Output				
Signal type	Range (mA)		Maximum allowable error (mA)	

Current output	4 ~ 20	±0.025
	0~20	±0.025
	0~10	±0.025

Wiring

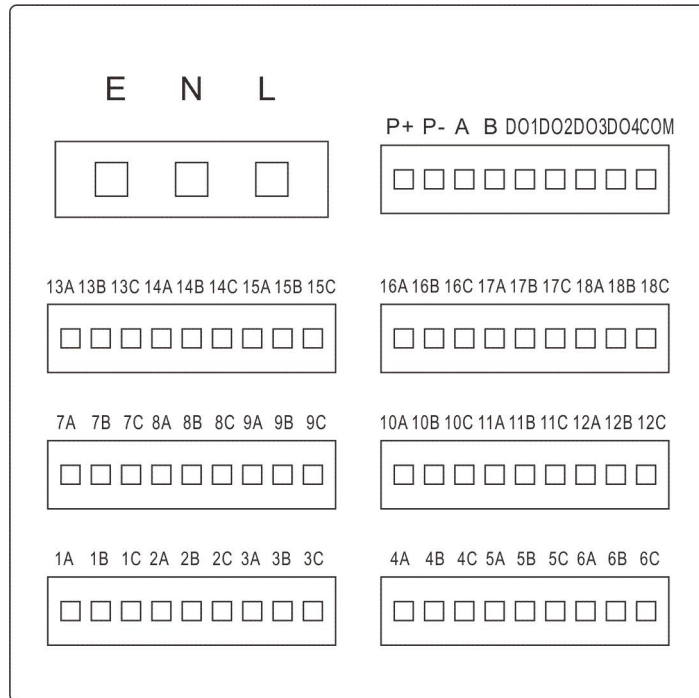

Figure 1 Schematic diagram of basic terminal

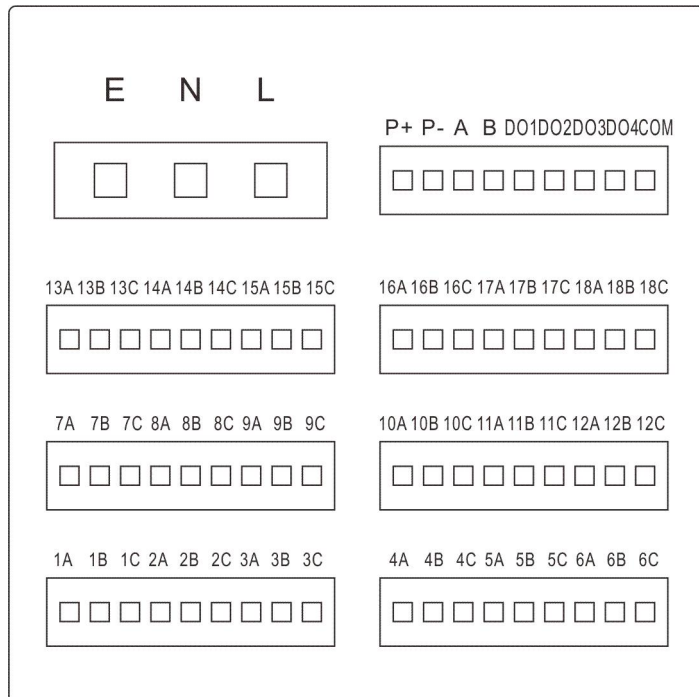

Figure 2 Schematic diagram of enhanced terminals

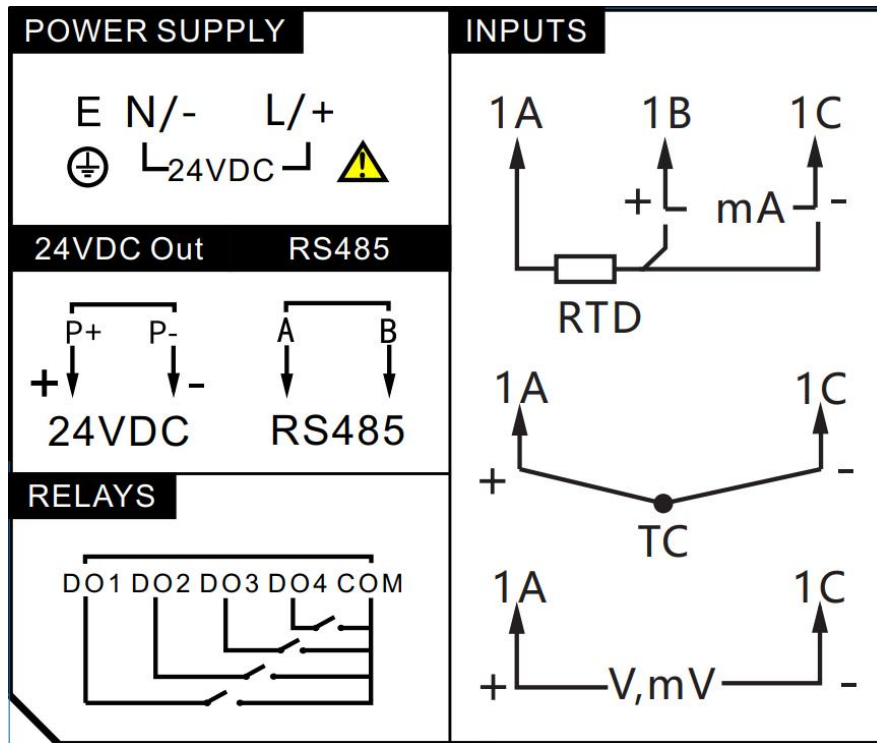

Figure 3 24V wiring diagram

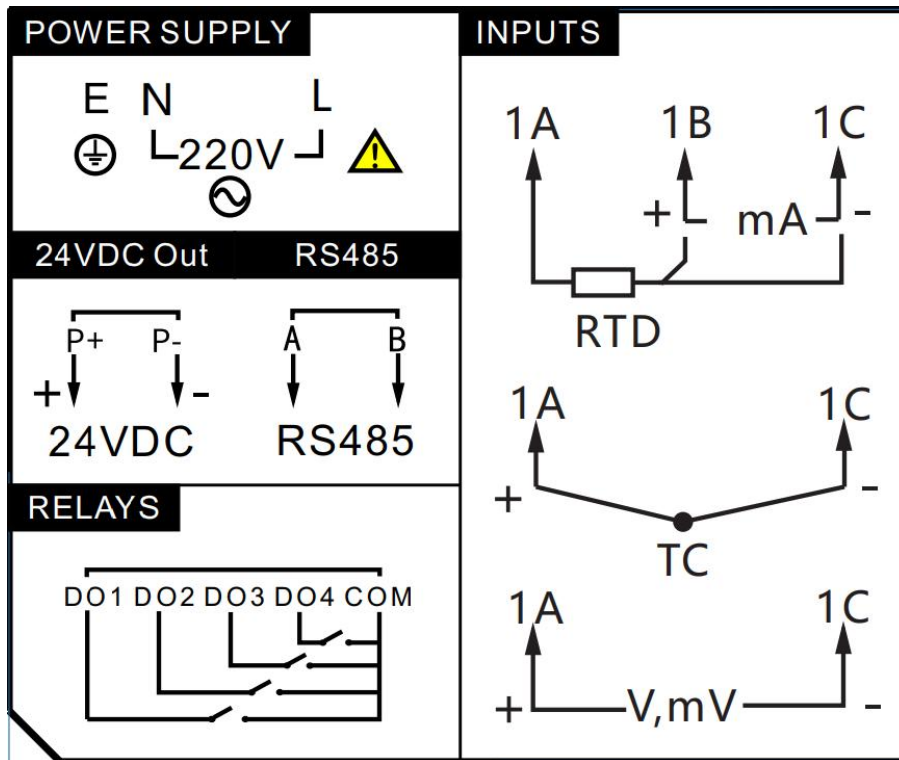

Figure 4 220V wiring diagram

Note:

The analog output board needs an external 24V power supply, which can be powered by the power distribution provided by this product. Due to the high power, try to avoid power distribution to other transmitters at this time.

Dimension

in mm

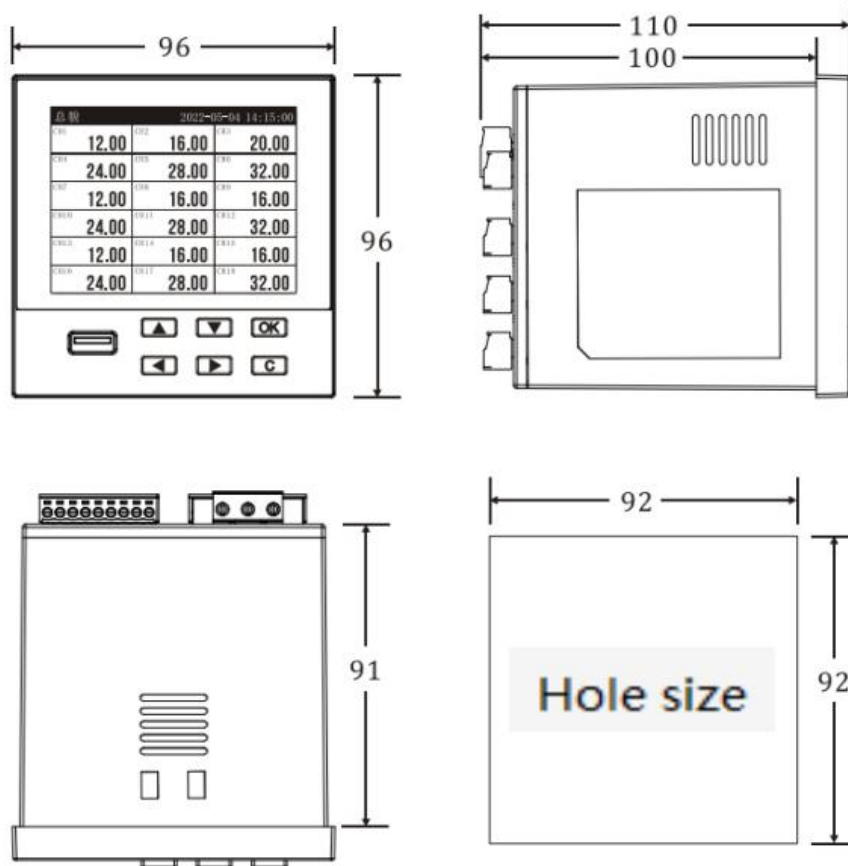

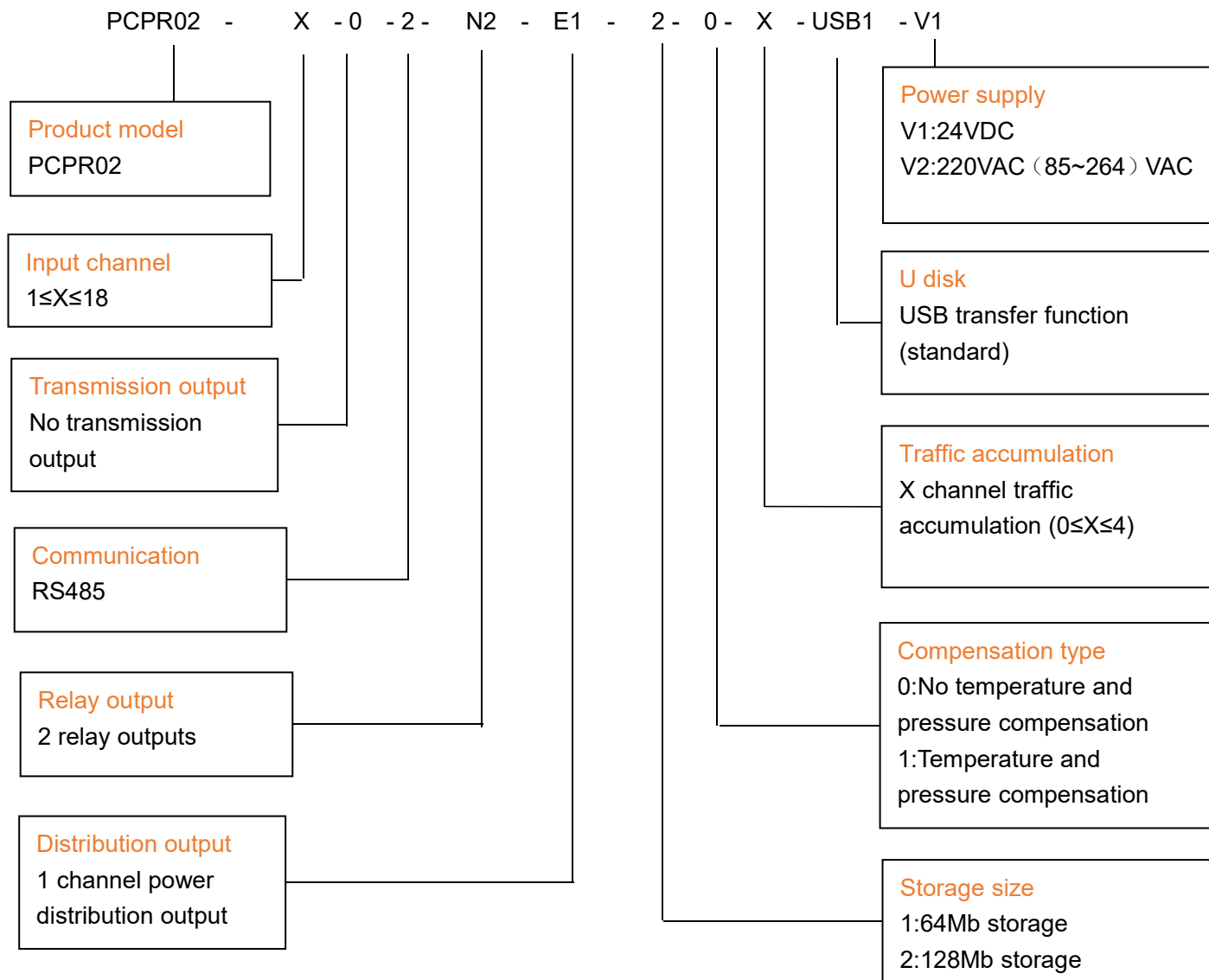

Example: PCPR02 X02N2E120XUSB1V1

Product model:PCPR02. X:Input channel 1≤X≤18. 0:No transmission output. 2:Communication RS485. N2:2 relay outputs. E1:1 channel power distribution output . 2:128Mb storage. 0:No temperature and pressure compensation. X:X channel traffic accumulation (0≤X≤4).USB1:USB transfer function (standard). V1:Power supply 24VDC.

Wotian reserves the right to make any change in this publication without notice. The information provided is believed to be accurate and reliable as of this product sheet.

Contact us

Nanjing Wotian Technology Co.,Ltd.

Website: www.wtsensor.com



Add: 5 Wenyong Road, Binjiang Development Zone, Nanjing, 211161, China
E-mail: dr@wtsensor.com